

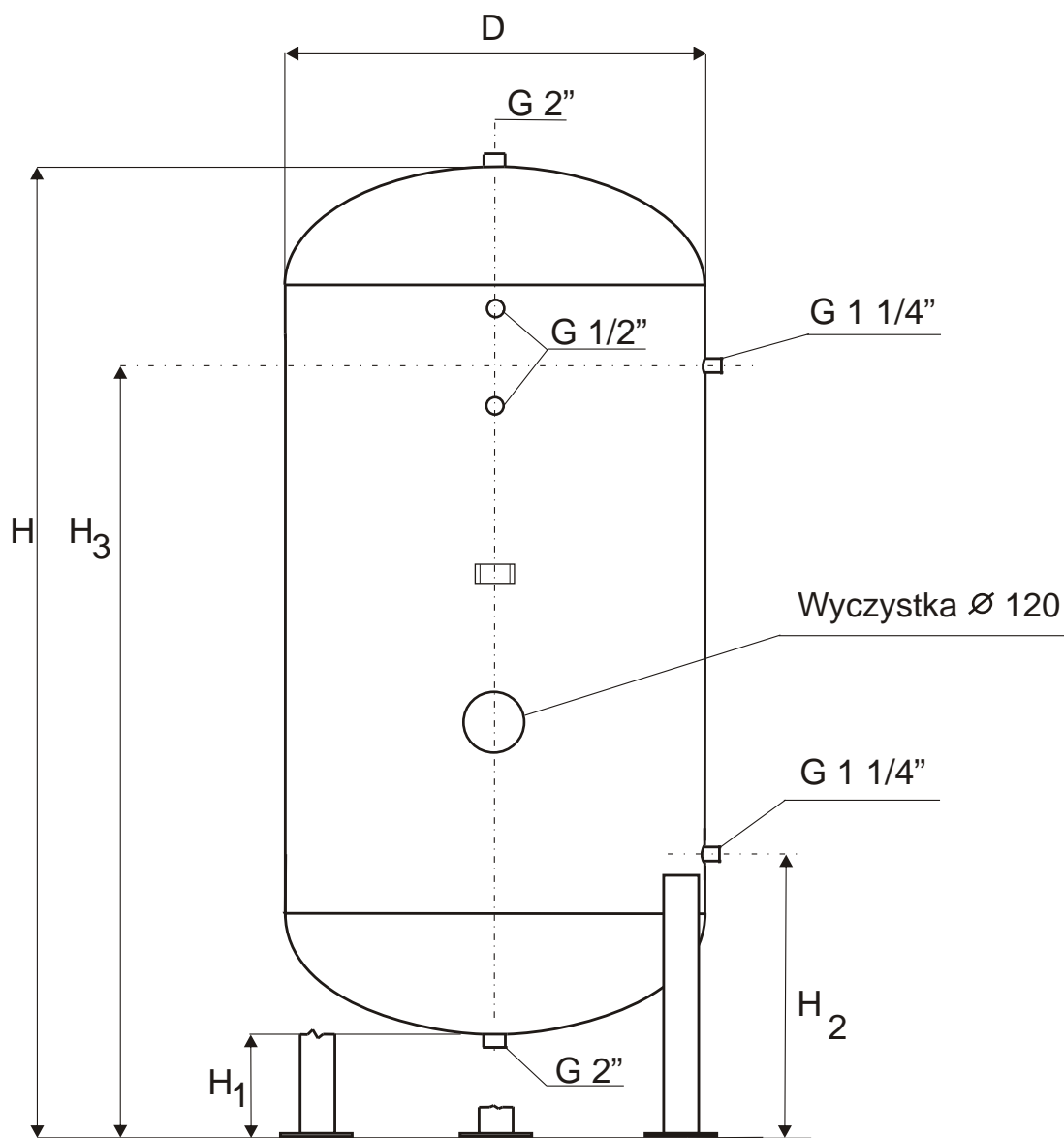

ZBIORNIKI SPRĘŻONEGO POWIETRZA

Dyrektywa 97/23/WE

karta nr 5



Uwaga! Zbiorniki preferowane jako standard

Lp.	TYP	V	PS	D	H	H1	H2	H3	MASA
		Litr	bar	mm					kg
1	ZP-1000/10	1000	10	900	2000	240	761	1411	270
2	ZP-1500/10	1500	10	1000	2357	240	836	1731	370